



INFO 65

BELLMER acquires Kufferath machine building division

Bellmer has acquired the former machine building division of Andreas Kufferath GmbH + Co KG of Düren, Germany.

Kufferath with its AKUPRESS® range is regarded as the world leader in screw press technology. Bellmer will operate this business through a new 100 %-owned subsidiary called Bellmer Kufferath Machinery GmbH, located in Düren. Bellmer has acquired Kufferath's 2,600 sq m production and assembly facility together with the surrounding site totalling 13,500 sq m. Bellmer Kufferath Machinery GmbH will be headed by former division executive Dr. Uwe Krieger, along with Bellmer managing partners Martin Kollmar, Erich and Philipp Kollmar.

Sales management will remain the responsibility of chief executive Thomas von Bothmer.

All 50 staff of the machine building division have been taken on by the new entity. Kufferath screw presses are mainly used for the treatment of rejects as well as dewatering sludge and fibre stock in the paper industry. Recent years have also seen the development of innovative applications for the separation / dewatering of waste and ferment substrates. Thanks to the AKUFORM® line, Kufferath machine building also has a worldwide reputation for dandy roll systems on special paper machines.

...to be continued on page 2



Screw press AKUPRESS BX 1400 – one of the largest screw presses in the world

BELLMER supplies paper machine for Glatz in Vietnam

Bellmer has won a major order from the leading international manufacturer of cigarette papers, Julius Glatz Group, which specified a paper machine to be installed in Vietnam. The special paper machine will be installed at the company's new premises near Saigon. For this project, Bellmer has assumed complete responsibility from approach flow to pope reel. This includes comprehensive engineering services as well as the associated

project management. Bellmer will supply a 4-stage cleaner plant as well as a TurboDrain™ Recovery TDR for

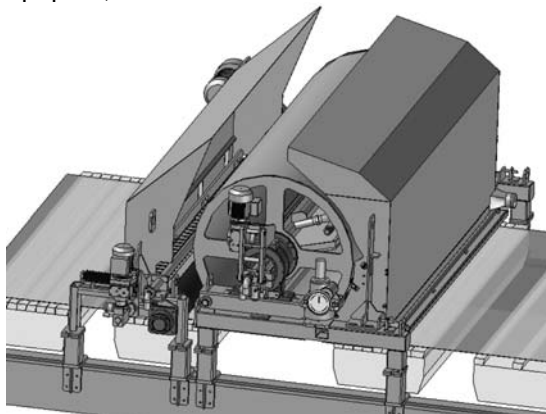

The special dandy roller ensures efficient dewatering

white water preparation. A headbox with rectifier rolls will ensure that this fine paper machine delivers consistent and reliable quality. The Bellmer EQUALShaker™ in combination with a new wire

section and a special dandy roller will ensure gentle dewatering.

...to be continued on page 3

Dear INFO Reader,

The continuous improvement of customers' operating processes using new innovations is a constant occupation for us here at Bellmer. The acquisition of the Kufferath machine building division is the perfect addition to Bellmer's product line. The advanced screw press technology is a particular case in point, as it gives access to further applications such as the treatment of rejects in the paper industry.

Julius Glatz Group has chosen Bellmer as its partner for the installation of a modern cigarette paper machine in Vietnam. And it is a particular pleasure to announce that our new subsidiary – Bellmer Kufferath Machinery – will provide the dandy roller for sheet formation.

Further interesting projects around the world are proof that Bellmer's innovative spirit is alive and well: Technocell Dekor will increase their paper machine's efficiency using our white water cleaning plant, which will be the biggest of its kind ever built by Bellmer.

Thanks to the WinklePress™ WPH, the SCA group at Ortmann in Austria can now make the same product with less fibre.

The paper mill AZPK in Russia can save on energy with solutions developed by our subsidiary company Lang-Hafner.

Daeyang Paper of South Korea has been able to enhance production considerably, thanks to TwinningPress™ shoe press.

How can we help you? Please get in touch.

We hope you enjoy Info 65.

Erich, Martin and Philipp Kollmar



Largest **BELLMER** white water cleaning plant: A further 4 TurboDrains™ TDR for Technocell Dekor

Felix Schoeller group is one of the most successful special paper producers in the world. At 6 locations in Germany and Canada, the company makes high quality products, such as imaging and décor papers.

The papers manufactured by the



TDR - well proven at Technocell Dekor

group's Technocell Dekor division provide the substrate on which incredibly authentic timber effects can be created, and these are used in applications from furniture to laminated floorings. Technocell Dekor supplies 200,000 tons per year of these grades, nearly

a third of the worldwide market of 630,000 tons. The Bellmer TurboDrain™ is used to treat white water, in order to achieve shorter machine cleanup times, between changes of colour for example.

Felix Schoeller group and Bellmer have enjoyed a highly successful business relationship: the prototype of the TurboDrain™ for white water II cleaning was first installed at Technocell Dekor in Günzach. Today, in addition to the Günzach site, TurboDrain™ systems operate in Osnabrück and Neustadt in Germany, and in Drummondville, Canada.

As part of a new strategy to focus more strongly on décor papers, paper machine No. 1 in Osnabrück is to be modified to allow production of décor papers as well as ink jet and thermo-transfer papers.

This unit was once the world's largest photo paper machine. In view of the planned productivity increase, the management decided to order

another four TurboDrains™ TDR 5 to optimise white water filtration. This will be the largest white water cleaning plant Bellmer has ever built.

Divisional project leader Marcel Pontius: "Experience with the TurboDrains™ in all our mills has been very good, so the use of new TurboDrains™ for the modernization of PM 1 was an obvious decision."

This is Technocell Dekor's eighth Bellmer filtration plant order, bringing the company's total TurboDrain™ tally to 19.



Thorough white water II cleaning

...continued from page 1

BELLMER acquires Kufferath machine building division

Kufferath machine building division also offers great service performance. Equipped with a top engineering facility and committed staff, the division carries out repairs swiftly and to a

high standard. Any interested company can rent as many mobile plants as are needed to develop and test new applications.

Bellmer and Kufferath machine build-

ing division's products complement one another perfectly. This development will assure Bellmer's market position as the leading manufacturer in the field of solid / liquid separation.

SCA Ortmann saves on fibres with the WinklePress™

SCA hygiene products group is Europe's market leader in tissue paper production. The company's mill in Ortmann, Austria, makes 123,000 tons a year of paper per year alone. SCA Hygiene Products has always been committed to active environmental protection and is equipped with a modern clarification plant.

To relieve the pressure on the environment still further, Dr. Armin Couperus (clarification plant manager) and Alois Siegl (technical specialist) studied and tested exhaustively the current dewatering technologies designed to deal with fibre residues from waste paper preparation.

They soon discovered the WinklePress™ WPH and its ability to achieve a very good dry contents level with a

comparatively modest energy input. Even more important was the fact that, thanks to the smooth and gentle



Dr. Armin Couperus (3rd from left) and Alois Siegl (2nd from right) together with the SCA team and Josef Waldoch from Bellmer after successful start-up

WinklePress™ press process, less fibre in the sludge was required to obtain optimum dewatering compared with their previous press. Dr. Couperus commented: "Finally, we have a press which conforms to the paper mill, rather than the other way round." This kills two birds with one stone: the process is better for the environment and saves energy costs at the same time. Thickening is carried out by a TurboDrain™ TDH-L.

Thanks to the integrated maturing chamber and an extra long straining zone, minimum additions of flocculent are required.

The project team working with Alois Siegl, together with Josef Waldoch of Bellmer, managed a highly successful start-up.

Daeyang enhances production with the TwinningPress™

Daeyang Paper in Seoul is the leading Korean manufacturer of corrugated board and testliner.

The Daeyang team is delighted with its new Bellmer TwinningPress™, which enjoyed a problem-free start-up. Erection and electric installations were performed by Bellmer's team in

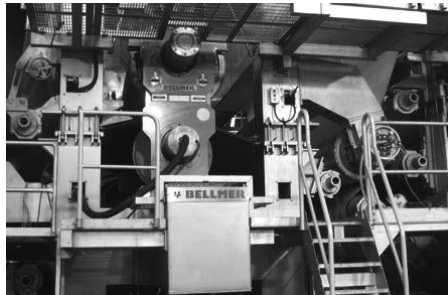

The newly installed TwinningPress™ at Daeyang

cooperation with the Daeyang staff in record time. The Machine has already been running for several months.

The shoe press, developed and built in cooperation with GapCon, features an operating width of 5 metres and an operating speed of 1,000 m/min – it is Bellmer's largest shoe press to date. It is also the first TwinningPress™ with counter roll technology, including hydrostatic components which make it especially suitable for wide and fast paper machines. Linear pressures up to 1,200 N/mm have become the norm thanks to this technology. Daeyang's management and production team followed the commissioning process with great excitement. The paper machine was successfully



All smiles - Daeyang and Bellmer start-up teams

started up just before Korean New Year's day. Thanks to the gentle pressure build-up in the shoe press, the packaging papers it produces are of an even higher quality than before.

Lang-Hafner economises on energy in Russia

The paper mill of AZPK, located 50 km from Arkhangelsk, makes natural-brown packaging papers on two board machines. Stable kraftliners with a basis weight of 125 g/m² are at present manufactured at speeds up to 530 m/min. In order to achieve a signifi-

rate heating for top and bottom.

For the air system, three outgoing and three additional air systems will be installed for the machine in the main evaporation zone area.

These additional ventilation units will ensure efficient air guiding in the wire

pockets and will ensure optimisation of CD moisture profiles. At the same time, they will ensure enhanced steaming power in the main evaporation zone area. To economise on energy, almost all the exhaust vapours and condensate from the steam and condensate system will be used by the three

additional air systems. The use of primary energy for air heating can be reduced to an absolute minimum as a result.

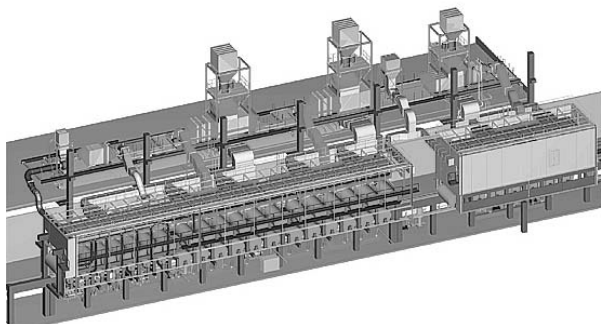

Energy-efficient air and heating technology from Bellmer

cant increase in production, the entire steam and condensate system is to be replaced. The rebuild of the steam and condensate system, as well as of board machine No. 2's air-system, is one of the first steps towards achieving higher speeds of up to 800 m/min. The drying section is equipped with a respectable 80 drying cylinders, featuring an operating width of 6,350 mm. The whole drying section will be divided in 6 heating groups.

Heating group 1 (vacuum group) up to heating group 4 will be arranged as a classical cascade system. Thermo-compressors will be installed in heating groups 5 and 6. Heating group 6 will be regulated by providing sepa-



Contract signing: Mr. Churakov, 1st deputy technical director (right in picture); Mr. Beloglazov, director general; Mr. Zhitnuchin, technical director; Mr. Thiel of Lang-Hafner (left in picture)

...continued from page 1

BELLMER supplies paper machine for Glatz in Vietnam

The Bellmer compact press is designed so it can respond flexibly to different product needs. Particular attention was paid to short draws.

The marking which is essential for cigarette paper can be adjusted with a special marking press. Paper strip transfer is effected using a combination of a rope guiding system and blow air transfer unit, known as Blow-Feed™.

The complete air technology as well as steam and condensate system will be the responsibility of Bellmer subsidiary Lang-Hafner.

In order to save on investment costs, Bellmer is to incorporate refurbished drying cylinders and rolls in Glatz's machine. Bellmer will undertake a thorough overhaul of these elements and integrate them into the new paper machine line.

Commissioning and start-up of the new mill is scheduled to take place during 3rd quarter of 2009.

The Glatz and Bellmer project teams have cooperated superbly right from the beginning.

Glatz's project leader Mr. Thomas Fritz complimented Bellmer on the fast and flexible service they have experienced so far.

BELLMER

Optimally shaken – not stirred! The **BELLMER** ShakerDay

In addition to its influence on the head-box and dewatering elements, breast roll shaking presents users with the opportunity to influence sheet formation sustainably.

Classical shaking systems are restricted in terms of the stroke frequency of mass inertia – this is quite in contrast to our new high-frequency shaking system **Turboshaker™**, which was presented to a large audience of experts during our **ShakerDay** in Niefern. Some highly-qualified speakers shared their considerable working expe-

rience of modern breast roll shaking with the paper industry audience. A live functional test of the **TurboShaker™** on location as well as a tour of the company's premises proved very popular among visitors.



Visitors during an on site inspection of the **TurboShaker™**

At the push of a button: Yield control with the **BELLMER SYSTEM CONTROL**

BELLMER SYSTEM CONTROL™ BSC for yield control has been developed in order to guarantee optimum yields from belt filter presses, even with variable mash qualities. Using this new system, apples of different varieties and ripeness can be balanced automatically, thus ensuring the best quality juice. The **Bellmer WinklePress™** automatically adapts to the input variables, so that less time and less per-

Index or set value and actual value are compared in the yield control system. If there is a difference between the two values, the mash volume will be adjusted accordingly. The height of mash is measured simultaneously at the belt filter press inlet. Constant mash height is maintained using belt speed control.

If the mash quantity changes, the height of mash at the press inlet will change correspondingly. The original mash height value can be re-adjusted by changing the belt speed. Change of mash quantity thus leads to a change of belt speed which, in turn, results in an alteration of retention time (pressing time) of the mash in the press. Yield can be changed and controlled by adjustments to pressing time.

The various sequences can be controlled easily via touch panel.

The **BSC Fruit** system has proved so successful that it has been patented.

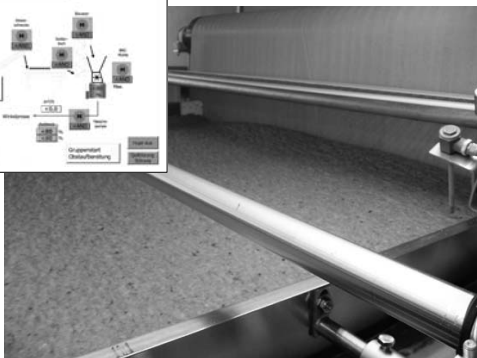
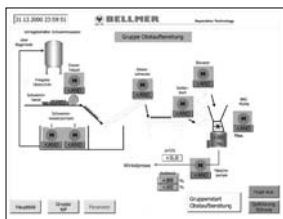

Automatic mash control for optimum yield

sonnel effort are required. The current yield values are determined through an evaluation of mash and juice supply rates. The operator simply enters an index value for the desired yield.

Great demand for the new **WinklePress™**

At the IFAT tradeshow, the No. 1 fair for waste disposal and environmental technology, Bellmer presented some comprehensive solutions to the problem of efficient sludge treatment to an international gathering of experts under the slogan "Sludge Treatment by the Specialist". The centrepiece of Bellmer's booth was the new **WinklePress™ WPN**, designed for lowest possible operating costs. The construction of Bellmer's top seller has been redesigned. The **WinklePress™ WPN** is the tool of choice when the user's target is to reach the lowest possible operating costs (flocculent,



Much interest was generated on Bellmer's booth

energy and maintenance). The many visitors to Bellmer's stand also had the opportunity to learn about innovations in the field of cost-effective thin slurry thickening using the **TurboDrain Compact™**. The **BELLMER FINE FILTER™ BFF** for membrane filtration in demanding applications such as waste water treatment and rainwater preparation, met with considerable interest, too. The great advantage of this process is the fact that it results in filtrate which is free from solids, without the addition of chemicals.

The response of the expert audience at IFAT was overwhelming. This international exchange of knowledge and experience is of paramount importance for sustainable environmental policies, particularly from a globalisation point of view. Such policies can no longer be implemented just at a national level, but only through international cooperation.



BELLMER

Gegr. 1842

Paper Technology Separation Technology

Gebr. Bellmer GmbH Maschinenfabrik • Hauptstraße 37 - 43 • D-75223 Niefern-Öschelbronn
Tel. +49 (7233) 74-0 • Fax +49 (7233) 74-100 • E-mail info@bellmer.de • <http://www.bellmer.de>